

## Product Brief

# TLE4928(C)

## Highly accurate differential Hall sensor for crankshaft and transmission applications

The TLE4928(C) detects the motion and position of ferromagnetic structures (e.g. pole or gear wheel) by measuring the differential flux density of the magnetic field. A self-calibration mode ensures optimum accuracy. The sensor only needs a few transitions after start-up then self-calibration has finished and reached a high-accuracy running mode. TLE4928(C) is switching at fixed hidden hysteresis, which is combined with a frequent recalibration function in run mode. This enables the sensor to accurately switch over lifetime (e.g. by run out events) and perform reliably, even under challenging conditions like vibrations such as seen in transmission applications.

The sensor combines a fast power up time with high accuracy and sensitivity. Providing a wide temperature range, high ESD robustness and large EMC resistance the TLE4928(C) perfectly meets the requirements of harsh environmental conditions, prevalent in automotive applications. The TLE4928(C) comes with the well established PG-SSO package - with and without two integrated capacitors. With all these features TLE4928(C) is the ideal fitting Hall based crankshaft and transmission speed sensing solution for today's automotive requirements.

TLE4928(C) is Perfectly Suited for Application Using:

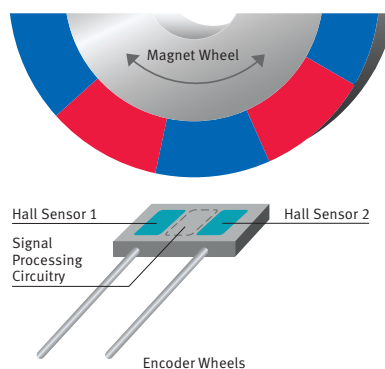
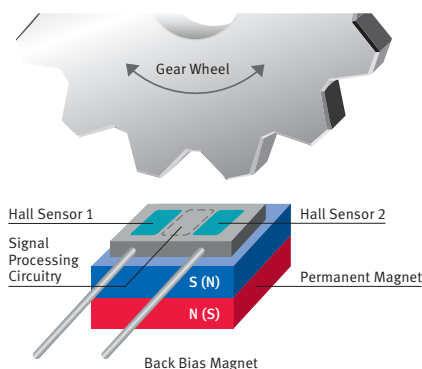

### Features

- High sensitivity
- Package options: PG-SSO-3-6 and PG-SSO-3-9 (2)
- Single chip solution
- Symmetrical thresholds
- High resistance to Piezo effects
- South and north pole preinduction possible
- Low cut-off frequency
- Advanced performance by dynamic self calibration principle
- Frequent recalibration in run mode
- Fast start-up time
- Large operating air-gaps
- Digital output signal (voltage interface)
- Reverse voltage protection at  $V_{S-pin}$
- Wide operating temperature range
- Short-circuit and overtemperature protection of output
- Module style package with two integrated capacitors:
  - 4.7nF between Q and GND
  - 47nF between  $V_S$  and GND: Needed for micro cuts in power supply



# TLE4928(C)

Highly accurate differential Hall sensor for crankshaft and transmission applications

**Block Diagram**

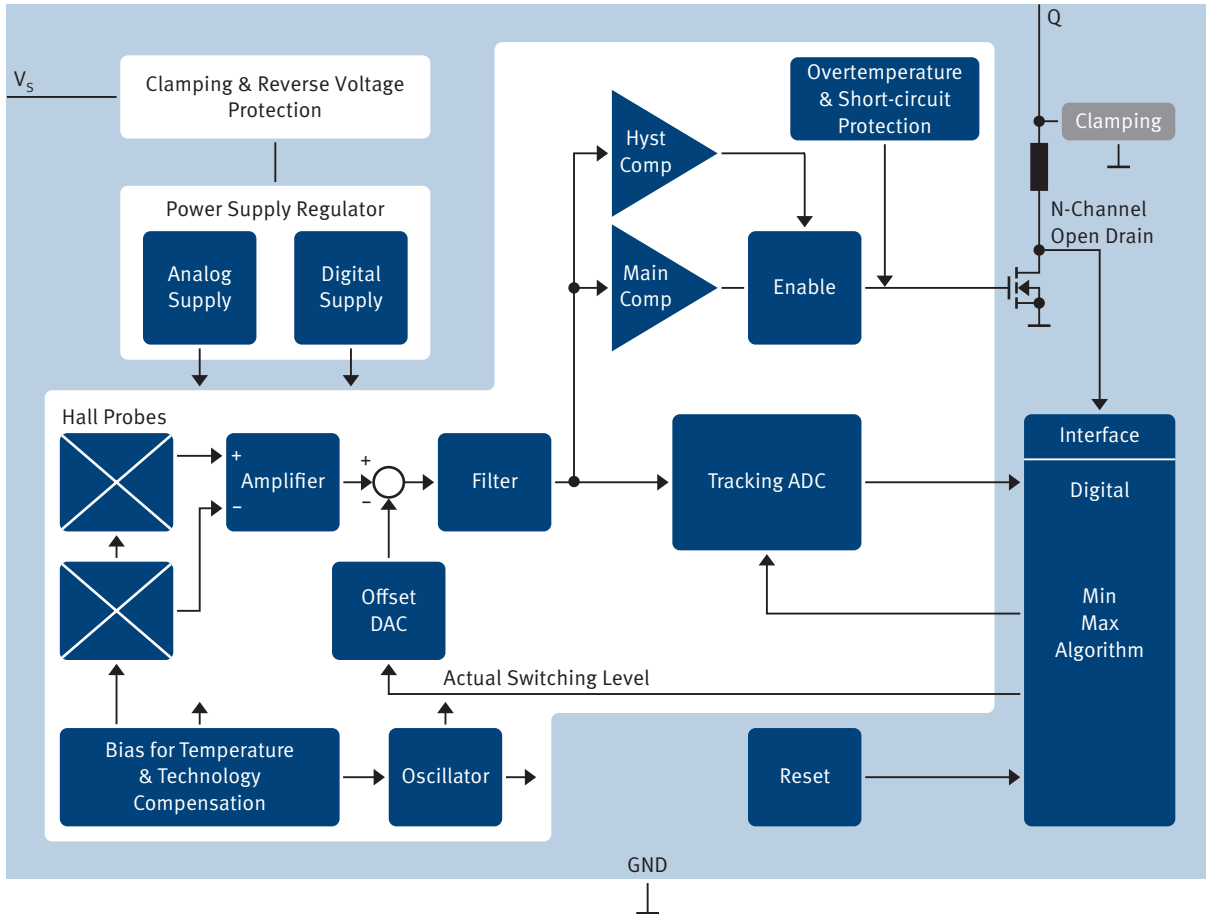

Sales Name	Description	Order Code
TLE4928	PG-SSO-3-6 package without external capacitors	SP000700818
TLE4928C-E6547	PG-SSO-3-92 package with external capacitors ( $V_s$ to GND: 47nF and Q to GND: 4.7nF)	SP000718274

Published by  
Infineon Technologies AG  
85579 Neubiberg, Germany

© 2013 Infineon Technologies AG.  
All Rights Reserved.

Visit us:  
[www.infineon.com](http://www.infineon.com)

Order Number: B142-H9822-X-X-7600  
Date: 08 / 2013

**Attention please!**

The information given in this document shall in no event be regarded as a guarantee of conditions or characteristics ("Beschaffenheitsgarantie"). With respect to any examples or hints given herein, any typical values stated herein and/or any information regarding the application of the device, Infineon Technologies hereby disclaims any and all warranties and liabilities of any kind, including without limitation warranties of non-infringement of intellectual property rights of any third party.

**Information**

For further information on technology, delivery terms and conditions and prices please contact your nearest Infineon Technologies Office ([www.infineon.com](http://www.infineon.com)).

**Warnings**

Due to technical requirements components may contain dangerous substances. For information on the types in question please contact your nearest Infineon Technologies Office. Infineon Technologies Components may only be used in life-support devices or systems with the express written approval of Infineon Technologies, if a failure of such components can reasonably be expected to cause the failure of that life-support device or system, or to affect the safety or effectiveness of that device or system. Life support devices or systems are intended to be implanted in the human body, or to support and/or maintain and sustain and/or protect human life. If they fail, it is reasonable to assume that the health of the user or other persons may be endangered.

单击下面可查看定价，库存，交付和生命周期等信息

[>>Infineon Technologies\(英飞凌\)](#)